

ollé

Instruction Manual of Induction hotplate

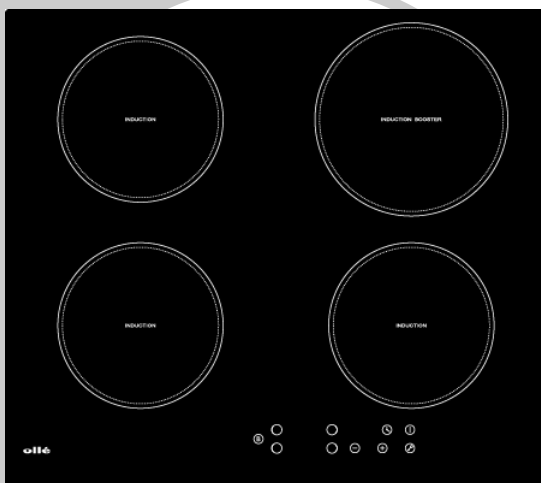

Model: MC-OL685

Thank you for purchasing the induction hotplate, please read this instructions manual carefully before using and keep it cautiously for your future reference.

Dear customer:

Thank you for purchasing the ollé induction hotplate our product can serve you many years to your satisfaction.

Please read this instructions manual carefully before using and installation, keep it cautiously after reading for future reference.

Thank you for your purchase of ollé induction hotplate again, and wish you to enjoy the pleasure by it.

Product Introduction

MC-OL685 induction hotplate can meet various of cuisine demands by electromagnetic heating, with micro-computerized control and multi-functions, really the optimal choice for modern families.

induction hotplate centers on customers and adopts personalized design. Made of imported materials and through advanced process, the unit has safe and reliable performances, making your life comfortable and enabling to fully enjoy the pleasure of life.

Working Principle

The induction hotplate is mainly composed of an induced heating coil, hotplate made of ferromagnetic materials and control system. In principle, current generates a powerful magnetic field via the coil. Large numbers of vortexes are produced in the way that the magnetic lines in the field contact the bottom containing iron or stainless steel substances. The tremendous energy generated by the vortexes can heat the food directly by converting efficiency heat energy penetrating through the bottom.

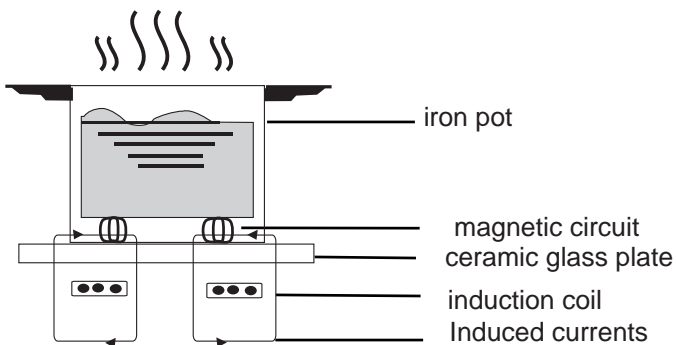

Safety

This product is designed for domestic use only

With a view to constantly improving our products, we reserve the right to make any changes to their technical, program or aesthetic features connected with their technical evolution.

1 Over- Temperature Protection

A temperature sensor equipped can monitor the temperature inside the hotplate. When an excessive temperature is monitored, the induction hotplate will stop operation automatically.

2 Detection of Small Articles

When the pot is less than 80 mm in diameter or small articles (knife, fork, forceps, key, etc.) exist or non-magnetic pots (such as aluminum pot) are found, the buzzer can give out an alarm lasting about 1 minute. In case the user has not put a proper pot in time, the induction hotplate can enter the state of standby automatically.

3 Heat Indication

When the hotplate is used for a long time, waste heat remains in the heating zone in a few minutes. The code "H" appears, warning to be away from the heating zone.

4 Auto shutdown protection

Auto shut down is a safety protection function for your induction hotplate. It shut down automatically if ever you forget to turn off your cooking. The default working times for various power levels are shown in the below table: .

Power level	The heating zone shut down automatically after
1~3	8 hours
4~6	4 hours
7~9	2 hours

When the pot is removed, the induction hotplate can stop heating immediately and shut down after the buzzer sounds for 1 minute.

* Remind:

People with a heart pacemaker shall use this product under the guidance of the doctor.

Installation

Selection of installation equipment

- 1 Cut hole on the kitchen benchtop according to the sizes shown in the drawing. For the purpose of installation and use, a minimum of 50 mm space shall be preserved around the hole. Be sure the thickness of the table surface is at least 30mm. Please select heat-resistant table material to avoid larger deformation caused by the heat radiation from the hotplate. As shown in Figure (1)

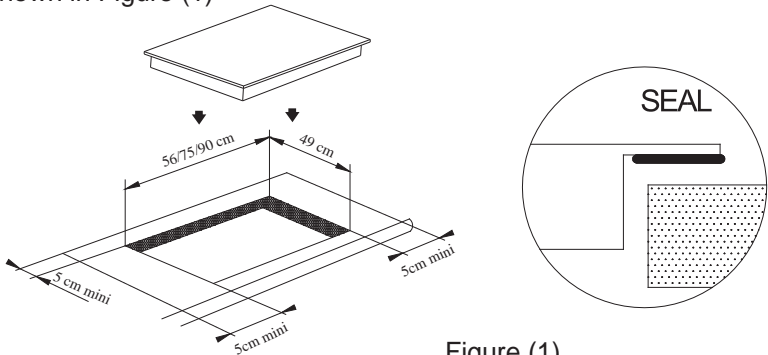

Figure (1)

- 2 Under any circumstances, make sure the induction hotplate is well ventilated and the air inlet and outlet are not blocked. Ensure the induction hotplate is in good work state. As shown in Figure (2)

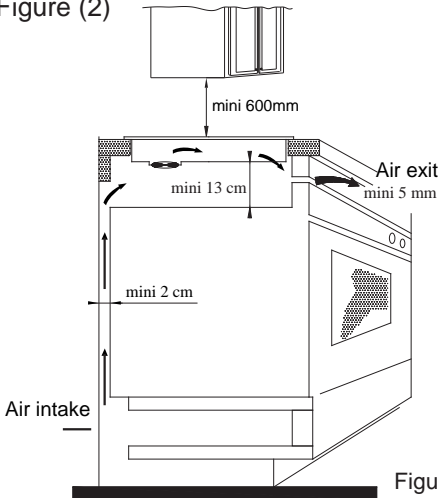
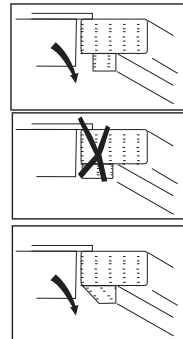
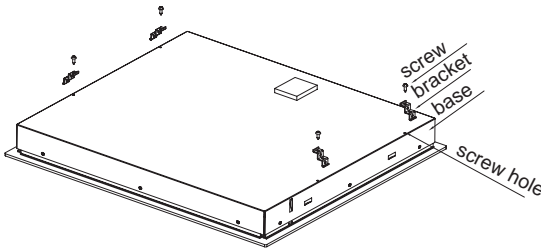

Figure (2)



Note: The safety distance between the hotplate and the cupboard above the hotplate should be at least 600mm.

- 3 Fix the hob on the kitchen bench by screw four brackets on the bottom of hob(see picture) after installation. Adjust the bracket position to suit for different bench thickness.



Cautions

1. The induction hotplate must be installed by qualified personnel or technicians. Please never conduct the operation by yourself.
 2. The induction hotplate shall not be mounted to cooling equipment.
 3. The induction hotplate shall be installed such that better heat radiation can be ensured to enhance its reliability.
 4. The wall and induced heating zone above the bench surface shall withstand heat.
 5. To avoid any damage, the sandwich layer and adhesive must be resistant to heat.
- 4 Power line connection

The socket shall be connected according to the relevant standard or connected to a single-pole cut-out. The method of connection is shown in Figure (3):

Vol tage&frequency	Wire connection				
400V 2-N 50\60HZ	1 • L1	2 • L2	3 •	4 • N	5 • ⏏
	Black	Brown	Gray&Blue		Yellow/Green
220-240V 50\60HZ	1 •	2 • L	3 •	4 • N	5 • ⏏
	Black&Brown		Gray&Blue		Yellow/Green
220-240V 2+2-N 50\60HZ	1 • L1	2 • L2	3 • N1	4 • N2	5 • ⏏
	Black	Brown	Gray	Blue	Yellow/Green

Figure (3)

If the cable is damaged or to be replaced, the operation must be carried out by a licensed electrician or technician. any accidents.

If the appliance is being connected directly to the mains an omnipolar circuit-breaker must be installed with a minimum opening of 3mm between contacts.

The installer must ensure that the correct electrical connection has been made and that it is compliant with safety regulations.

The cable must not be bent or compressed.

The cable must be checked regularly and replaced by authorised technicians only.

Induction hotplate appearance

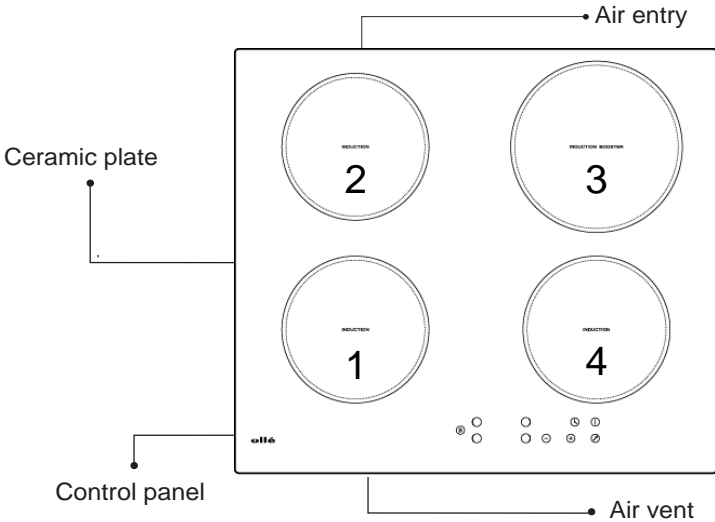

Schematic diagram of the control panel

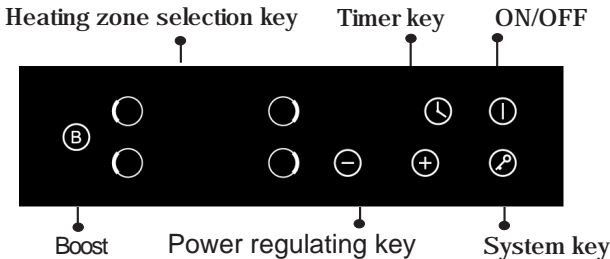

Instructions for Use

Preparation before using:

After power on, the buzzer beep once, all the indicators light up for 1 second then go out, indicating the induction hotplate enters the state of standby.

Put the pot in the center of the heating zone.



Operation Instructions

After the "ON/OFF" key is pressed, all the indicators show "-". According to the heating zone where the pot is placed, select a relevant zone selection, with a corresponding power level indicator flashing. At the moment, press the "+" or "-" button, the indicator displays 5, then adjust the power levels using the "+" or "-" button. Press the "+" and "-" button simultaneously, the hotplate immediately returns the power setting to 0 and all the cooking zone switches off.



See the attached table on PAGE 8 for the power specific to each heating zone.

Note: After the "ON/OFF" key is pressed, the induction hotplate will restore to its standby state if no any operation is carried out within two minutes.



Boost function

To get a quicker heating speed, directly press "BOOST" after selecting the heating zone, with the power level indicator showing "P." This function can reach the heating power of up to 2600W.



Note:

1. The boost function only operates for 5 minutes, after which the cooking zone returns to its original setting.
2. The boost function only works on the third cooking zone.
3. As the boost function is activated, the 4th cooking zone is limited under level 2 automatically.



Cancellation of "BOOST" function

Select the third cooking zone and press the "Boost" key to cancel the Boost mode, then the cooking zone will revert to its original setting.

When in "Boost" mode, press the "-" key to set the cooking level to "9".

Timing function

Press the timing key, then the indicator flashes, and at this point, you can set time. Using the "+" and "-" keys, you can realize the setting of timing from 1 to 99 minutes. When the "+" key is pressed, the set time will increase by 1 minute; when the "-" key is pressed, the set time will decrease by 1 minute; when the set time exceeds 99 minutes, it will restore to 0 minute automatically. If press the "+" and "-" simultaneously, the indicator displays 0.



Timing confirmation:

1. Select the power level of the cooking zone, then press the "Timer" button, you can set the timer.
2. Once the timing indicator flashes for 5 seconds, the set time will be confirmed to be valid automatically.
3. After selecting a set time, press the "Timing" key, confirming its effectiveness.

Timing cancellation:

After setting time again, hold the "Timer Key" for 5 seconds, then the timing can be cancelled automatically, with the timing indicator showing "0".

System function: to ensure the safety of children, the induction hotplate is provided with the function of interlock.

Locking: Press the "Interlock" key, then the induction hotplate enters the locking state, with the timing indicator showing "L0" and the rest keys disabled.



Unlocking: under the locking state of the induction hotplate, hold the "Interlock" key for 2 seconds, removing the locking state automatically.

The max. power of each heating zone are as follows:

Heating zone	Max. power (W)	
	Normal	Boost
1	2000	-----
2	1400	-----
3	2000	2600
4	1400	-----

The above power may vary if the material or the size of pot is different.

Selection of heating appliances



Iron oil frying pan



Stainless steel pot



Iron pan



Iron kettle



Enamel stainless steel kettle



Enamel cooking utensil



Iron plate

You may have multiple appliances suitable for heating.

- 1 This induction hotplate is able to identify multiple heating appliances, and you can test them according to one of the following methods:

Place the appliance in the heating zone. If the corresponding heating zone displays a power level, it shows the suitability of the appliance; if "U" flashes, it shows the appliance does not fit in the induction cooking.

- 2 Have a magnet to contact the appliance. If there is attraction between them, it shows the appliance also fits in the induction cooking.

* Requirement for pot material: the bottom contains materials of magnetic conductivity.

* Requirement for shape: flat bottom, more than 12 cm in diameter.

Safety Reminding and Maintenance:

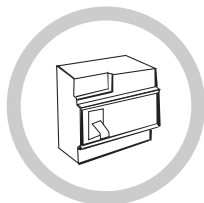

Please use a dedicated power protection air switch;

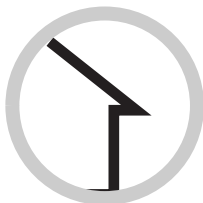

Indoor use only.



Never directly wash the induction hotplate with water so as to avoid dangers.



Never have the induction hotplate to work without food inside, otherwise its operational performance may be affected and danger may happen.



For sealed food such as canned goods, please do not heat them before opening their covers so as to avoid any dangers of explosion due to heating expansion.

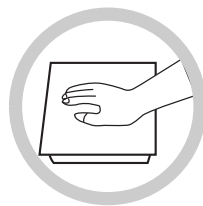

After being used for a long time, the corresponding heating zone of the induction hotplate is still hot. Never touch the ceramic surface to avoid burning.

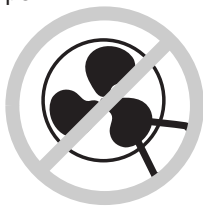

We suggest that you should periodically check that there are no object (glass, paper, etc) that could obstruct the inlet under your induction hotplate.



Metallic objects such as knives, forks, spoons and lids should not be placed on the hotplate since they can get hot.



Never use the induction hotplate in high temperature environments such as near a gas stove or kerosene stove.



Do not put any detergents or flammable materials in the equipment installed under the induction hotplate.



If the surface is cracked, switch off the appliance to avoid the possibility of electric shock.



Do not place rough or uneven appliances, which may damage the ceramic surface.



Clean the induction hotplate on a regular basis to prevent foreign matters from entering the fan thus influencing the normal operation.



Keep electrical appliance out of reach from children or inform person. Do not let them use the appliances without supervision.

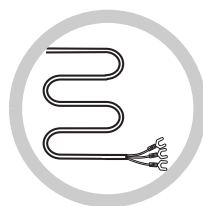

If the supply cord is damaged, it must be replaced by the manufacturer, its service agent or similarly qualified persons in order to avoid a hazard.

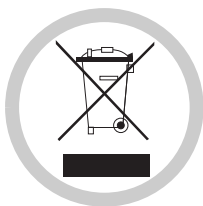

DISPOSAL: Do not dispose this product as unsorted municipal waste. Collection of such waste separately for special treatment is necessary.

Cleaning and Maintenance

You can easily clean the surface of the induction hotplate if following the methods given in the table.

Type of contamination	Method of cleaning	Articles used for cleaning
Light	Wipe with a damp cloth	Cleaning sponge
Accumulation of dirt	Spray with water then wipe it dry with abrasive sponge	Special cleaning sponge for ceramic glass
Rings and lime crumbles	Apply white vinegar to the polluted zone, then wipe it dry with soft cloth or a special article for ceramic glass	Special adhesive for ceramic glass
Sweetmeat, melt aluminum or plastics	Use a scraper suitable for ceramic glass (to protect glass, a silicon product is preferred) to remove residuals	Special adhesive for ceramic glass

Hint: please disconnect power before the cleaning.

Failure Display and Inspection

If an abnormality comes up, the induction hotplate will enter the protective state automatically and display corresponding protective codes:

Troubles	Possible reasons	Solutions
F0/F1/F2	Fan failure	Please contact the supplier
F3-F8	Temperature sensor failure	Please contact the supplier.
E1/E2	Abnormal supply voltage	Please inspect whether power supply is normal. Power on after the power supply is normal.
E3/E4	Abnormal temperature	Please inspect the pot.
E5/E6	Bad hotplate heat radiation	Please restart after the hotplate cools down.

The above are the judgment and inspection of common failures.
Please do not disassemble the unit by yourself to avoid any dangers and damages to the induction hotplate.

Customer Care Service

Before contact the service agent

We suggest to check the following first:

-verify if the plug is correctly inserted in the socket

-read the Failure and Display table above

In case it is not possible to establish the reason for the bad functioning of the appliance:

switch it off, do not try to manumit it and call contact the Service agent.

Special Declaration

All the contents in this material have been subjected to careful check. For any mistake and omission in printing or misunderstanding of the contents, the company keeps the right of interpretation.

Addition: any technical improvement will be placed in the revised manual without notice; for product appearance and color is according to the actual one
